

RAIN HARVESTING
by Blue Mountain Co

+61 (0)7 3248 9600

rainharvesting.com.au

RAIN HARVESTING
by Blue Mountain Co

Maintenance Tray



PRODUCT DETAILS

The Maintenance Tray solves the challenge of cleaning fixed and difficult-to-reach tank inlet screens. It sits on top of these screens to become a second, removable screen with an easy-to-reach protruding handle.

TMTG01 300mm
TMTG02 400mm

FEATURES AND BENEFITS

- Protects tank screens from the build up of leaves and debris
- Easy to use – just lift the Tank Guardian off the tank screen by the easy grip handle and remove debris
- Easy to install – no tools required, simply place on top of the existing tank screen
- 0.955mm stainless steel screen

Installation

WHAT'S IN THE BOX?

- Maintenance Tray

MAINTENANCE TRAYS

1. Clean your tank inlet screen to remove any leaves or debris. If necessary, remove your tank inlet screen to clean it thoroughly, then reinstall it.
2. Place your Maintenance Tray on top of your tank inlet screen.

MAINTENANCE

You should regularly clean your Maintenance Tray to ensure the water flowing into your rainwater tank isn't obstructed or contaminated by leaves and debris.

To clean, grab the handle, remove your Maintenance Tray from your tank screen and brush away larger leaves and debris. If necessary, you can hose it off remove any finer debris. Replace on top of your tank inlet screen.

To improve your rainwater quality, we recommend inspecting your Maintenance Tray every 3 months or between rainfall events.

Alternatively, you may wish to consider installing a Maelstrom Filter rather than using a Tank Screen and Maintenance Tray.

PRODUCT DIMENSIONS

TMTG01 300MM

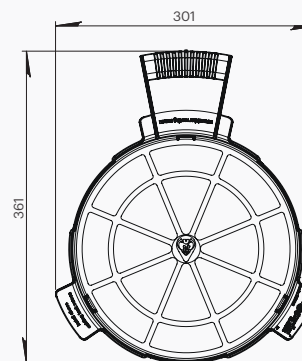

TOP VIEW

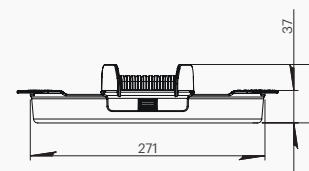

SIDE VIEW

TMTG02 400MM

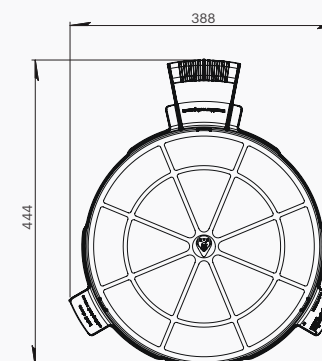

TOP VIEW

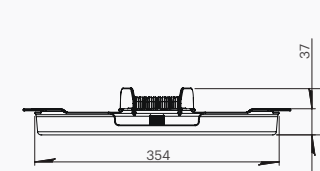

SIDE VIEW

ALL DIMENSIONS IN MM UNLESS OTHERWISE STATED.

DISCLAIMER This product specification is not a complete guide to product usage. Product specifications may change without notice. For more information visit rainharvesting.com.au. Keep this manual handy for future reference. © Rain Harvesting Pty Ltd.

COMPLIANCE

- AS/NZS 4020:2005 - Testing of products for use in contact with drinking water