

## RAIN HARVESTING

by Blue Mountain Co

+61 (0)7 3248 9600

[rainharvesting.com.au](http://rainharvesting.com.au)

## RAIN HARVESTING

by Blue Mountain Co

# First Flush Downpipe



## Installation and Specification Guide

### PRODUCT DETAILS

Protect your rainwater quality by diverting the “first flush” of the most contaminated water from your roof away from your rainwater tank

WDDP01 90mm

WDDP02 100mm

### FEATURES AND BENEFITS

- Minimise the fine and dissolved organic and inorganic particles entering your tank
- Reduce sediment build-up in your tank and sediment load on your post-tank pumps and filtration systems
- Protect household fixtures and appliances (ie. washing machines, toilet cisterns, etc.) by lowering sediment and tannin deposits
- Reduce nutrient load in your tank to limit anaerobic fermentation and algae growth
- Diversion volume easily custom built through use of standard pipes.
- Automatic reset valve drains after rainfall events
- Comes in kit form

# Installation

## WHAT'S IN THE BOX?

1. Ball Seat x 1
2. Flow Control Valves x 8
3. Plastic Filter Screen x 1
4. Pipe/wall Bracket x 2
5. Tee Junction x 1
6. Sealing Ball x 1
7. Screw Cap, Hose Connector & Socket x 1



## TOOLS/MATERIALS YOU MAY REQUIRE

- 90mm or 100mm pipe (for diversion chamber)
- Tape measure
- Marker pen
- Saw
- Sealant
- Solvent weld glue
- Screws
- Drill or screwdriver

## 90MM MODEL

1. Determine the length of 90mm pipe required for your first flush diversion chamber. As a rough guide: 1 metre of 90mm pipe holds approximately 5.9 litres of water. Ensure all cut edges are clean and smooth.
2. Attach the threaded coupling to your diversion chamber pipe applying solvent weld glue to the socket of the coupling and pipe, then push together and hold until the glue sets.
3. Select the appropriate flow control washer and fit it into the hose connector with the side marked "TOP" showing. Start by using the Control Washer with the smallest gauge hole (lowest number). Try a larger gauge Washer if experiencing blockages. Save the remaining washers for possible future use. Insert the plastic filter screen in through the base of the screw cap with O-ring seal and secure by attaching the hose connector and flow control washer.
4. Attach the screw cap with O-ring seal (and assembled components) to the threaded coupling.
5. Measure your existing downpipe and cut to create space for the T-junction. The outlet of your diverter must sit at least 150mm from the ground when fully assembled, so select your installation point and measure and cut accordingly. Ensure all cut edges are clean and smooth.
6. Connect the T-junction to the existing downpipe and install with solvent weld glue in the same manner as step 2.
7. Place the ball inside your first flush unit through the upper end of the diversion chamber pipe.

## PRODUCT DIMENSIONS

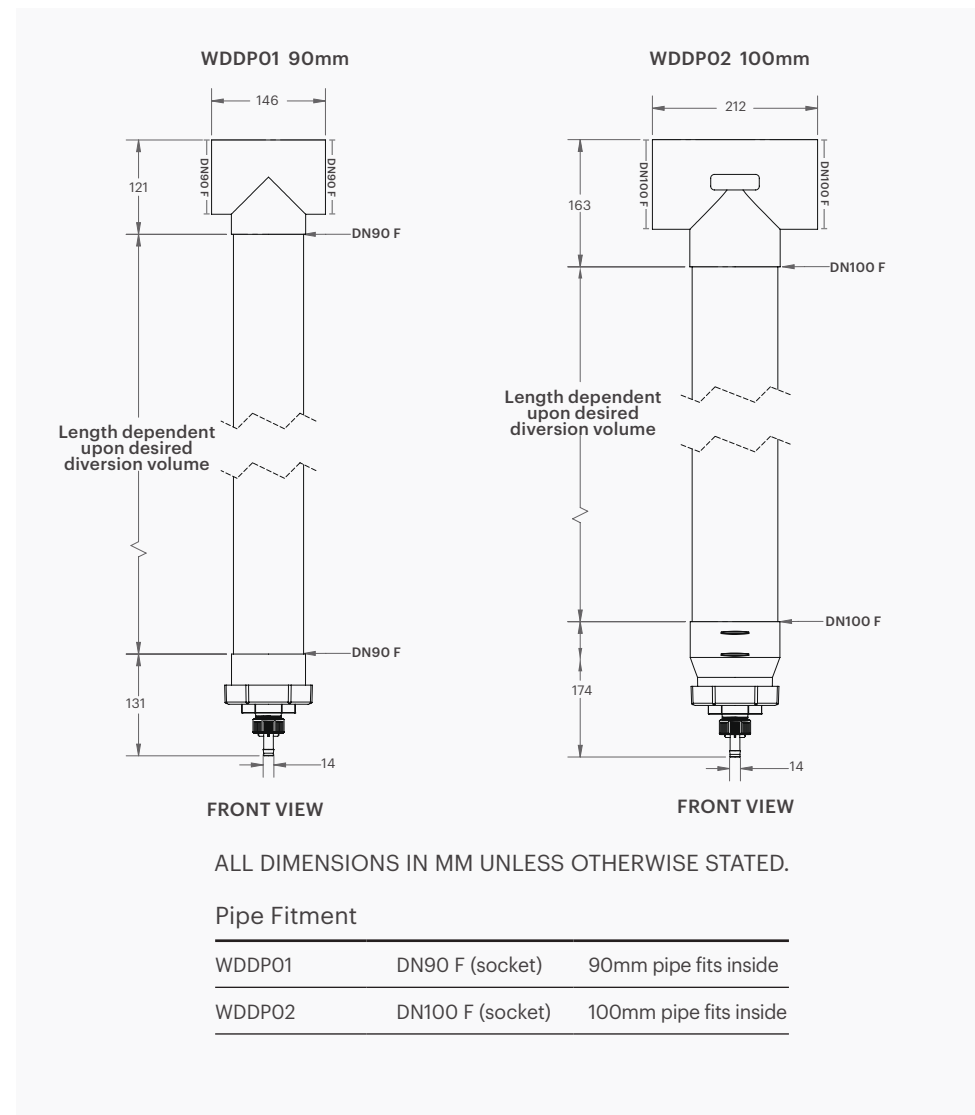

DISCLAIMER This product specification is not a complete guide to product usage. Product specifications may change without notice. For more information visit [rainharvesting.com.au](http://rainharvesting.com.au). Keep this manual handy for future reference. © Rain Harvesting Pty Ltd.

## COMPLIANCE

- AS/NZS 4020:2005 - Testing of products for use in contact with drinking water

## 100MM MODEL CONT.

9. Place the ball inside your first flush unit through the upper end of the diversion chamber pipe.
10. Apply glue to the T-junction and upper end of the diversion chamber pipe and insert the pipe into the junction and hard up against the ball seat, holding until the glue sets.
11. Position your assembled first flush diverter in place and attach to the wall using the supplied brackets, supporting the unit until it is fully secured. The upper bracket must sit directly under the T-junction, where it will hold the weight of the unit.

## MAINTENANCE

It is important to ensure that your first flush diverter outlet remains clear of any debris. If your outlet becomes blocked, the chamber will not empty and the first flush of water will not be diverted when it rains.

To ensure the flow of water through your diverter's outlet, periodically unscrew the outlet to allow debris to fall out. If the diversion chamber is full of water, take care as it empties. Remove the hose connector, flow control washer, and filter screen and hose or wash the screen with clean water. Check the flow control washer for any blockages and remove and clean as necessary.

For best results and minimal maintenance, we recommend installing rain heads such as our Leaf Eater rain heads on all your downpipes to limit the volume and number of leaves and debris that reach your first flush diverter.

## POLLUTION FACTORS

POLLUTION FACTOR FOR THE ROOF	
MINIMAL POLLUTION	SUBSTANTIAL POLLUTION
<p><b>DIVERT 0.5L PER M<sup>2</sup></b> Open field, no trees, no bird droppings, clean environment</p>	<p><b>DIVERT 2L PER M<sup>2</sup></b> Leaves and debris, bird droppings, various animal matter, e.g. dead insects, skinks, etc.</p>
<p>The above quantum are the results of preliminary testing. Individual site analysis and field testing is required to more accurately assess the quantum to be diverted in each individual case</p>	

## DIVERSION FACTORS

DIVERSION FACTOR FOR A FIRST FLUSH WATER DIVERTER	
MINIMAL POLLUTION	SUBSTANTIAL POLLUTION
<p><b>M<sup>2</sup> ROOF AREA X POLLUTION FACTOR</b> = <b>LITRES TO BE DIVERTED</b></p>	
<p><b>Example for a minimal polluted roof of 100m<sup>2</sup></b> 100 x 0.5 = 50 Litres to be diverted</p>	<p><b>Example for a heavily polluted roof of 100m<sup>2</sup></b> 100 x 2 = 200 Litres to be diverted</p>

1m of 90mm pipe = 5.9 litres / 1m of 100mm pipe = 8.8 litres

## REFERENCE CHART

### REFERENCE CHART

1	Diverter Chamber	7	Chamber Inlet	12	Pipes/Wall Brackets
2	In-feed from the roof	8	Chamber Outlet	13	Plastic Filter Screen
3	To the tank	8b	Elbow	14	Socket
4	Diverter Chamber	9	Ball Seat	15	'O' Ring Seal
5	Sealing Ball	10	Screw Cap	16	Hose Connector
6	Tee Junction	11	Flow Control Valve		

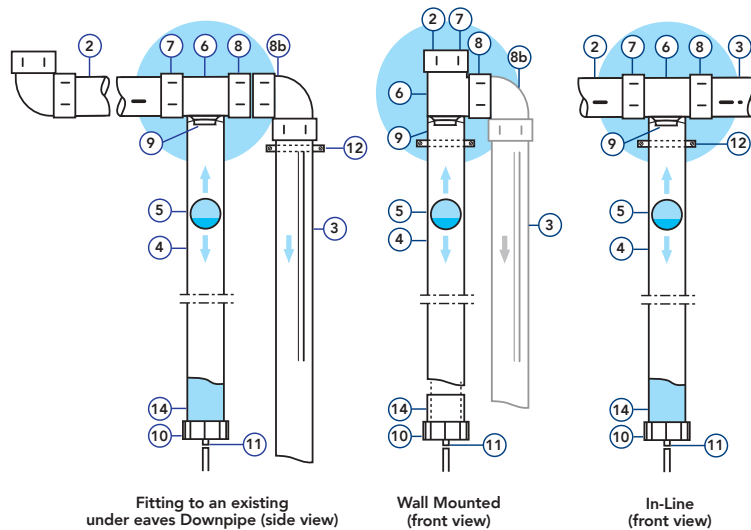

Assembled end cap with  
Optional Primary Screen

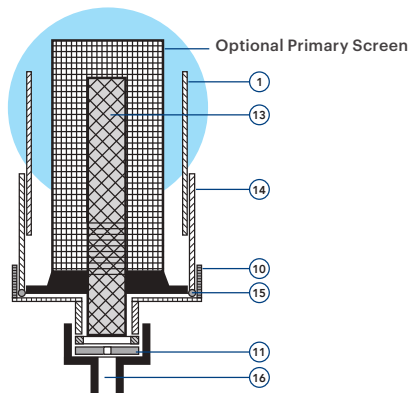

## 90MM MODEL CONT.

- Insert the ball seat into the T-junction, with the narrow end of the seat facing down.

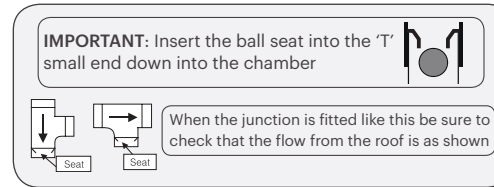

- Apply glue to the T-junction and upper end of the diversion chamber pipe and insert the pipe into the junction and hard up against the ball seat, holding until the glue sets.
- Position your assembled first flush diverter in place and attach to the wall using the supplied brackets, supporting the unit until it is fully secured. The upper bracket must sit directly under the T-junction, where it will hold the weight of the unit.

## 100MM MODEL

- Determine the length of 100mm pipe required for your first flush diversion chamber. As a rough guide: 1 metre of 100mm pipe holds approximately 8.8 litres of water. Ensure all cut edges are clean and smooth.
- To attach the threaded coupling to your diversion chamber pipe, insert a length of male 100mm pipe inside the threaded coupling and glue in place using an appropriate sealant. Glue the other end inside your diversion chamber pipe. Attach the threaded coupling to your diversion chamber pipe applying solvent weld glue to the socket of the coupling and pipe, then push together and hold until the glue sets.
- Select the appropriate flow control washers and fit it into the hose connector with the side marked "TOP" showing. Save the remaining washers for possible future use. Start by using the Control Washer with the smallest gauge hole (lowest number). Try a larger gauge Washer if experiencing blockages. Save the remaining washers for possible future use.
- Insert the plastic filter screen in through the base of the screw cap with O-ring seal and secure by attaching the hose connector and flow control washer.
- Attach the screw cap with O-ring seal (and assembled components) to the threaded coupling.
- Measure your existing downpipe and cut to create space for the T-junction. Your diverter must sit at least 150mm from the ground when fully assembled, so select your installation point and measure and cut accordingly. Ensure all cut edges are clean and smooth.
- Connect the T-junction to the existing downpipe and install with solvent weld glue in the same manner as step 2.
- Insert the ball seat into the T-junction, with the narrow end of the seat facing down.

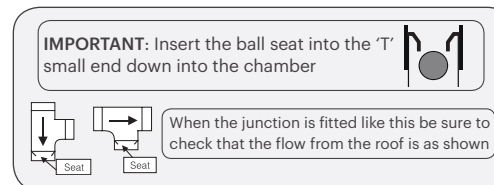

Continue overleaf for remaining instructions.